



Table of contents

Panel radiators

GENERAL / GUARANTEE	3
ECOSTYLE	4
Technical data and radiator dimensions	4
Connections	5
Output Tables	6
Correction Factor Table	7

General

The Biasi radiators are produced from high-quality material and components.

EXCELLENT HEAT OUTPUT

Modern radiators have remarkably low water content to ensure fast heat-up and high output. The low water content combined with large convector plates radiate heat in a highly efficient way.

HEATING SYSTEM

Biasi radiators are designed for use on closed heating systems, where the free access of oxygen is prevented. A compact, well planned and constructed system saves energy and components making up the system. Draining the system requires more fresh water, which result in rust on the inside of the steel surface. Due to this it is not advisable to empty the heating system for the summer. The water temperature should be between 0 to 210°F and the pH value between 7 and 9.

PRESSURE RATING

The working pressure of Biasi radiators is 87 psi. It must not be exceeded when planning the heating system. In heating systems of tall buildings one also has to remember the dynamic, additional pressure given by the pump, beside the normal hydrostatic pressure. All Biasi radiators are pressure tested during production.

Guarantee

Each Biasi radiator is guaranteed for 10 years from the date of installation against defects caused by faulty materials or manufacture. The defective product is replaced by a similar or technically corresponding radiator.

The guarantee does not cover damages that are due to faulty storage and handling at delivery or installation, nor damages that are due to faulty use of the radiator, such as inside and outside rust, use or corrosive substances, too high pressure or damage due to freezing.

The guarantee does not cover incidental damages caused by the Biasi

MOUNTING

Current directives and generally accepted practices must be followed when the radiator is mounted. It is not recommended to remove the plastic cover until all the construction work is completed. The wall must always be checked before the brackets are mounted to ensure it can support the weight and use of the radiator. The Ecostyle radiators are supplied with clamp bracket for easy mounting.

APPLICATION ENVIRONMENT

Biasi radiators are intended for heating dry rooms. In case they are mounted in bathrooms, the mounting must always be on dry walls and not directly under a shower or similar fixture.

product, costs for change of product, production loss of the customer, unreceived profit or other indirect costs.

In case of a guarantee claim the buyer must contact the seller and present of evidence of purchase of the product, for example, order confirmation, delivery note or identification number of the radiator. The defective product must always be sent back to Biasi for inspection within one month from the day of complaint, if not otherwise agreed upon.



Ecostyle

Technical data

Material	Cold rolled steelplate EN 10130
Surface treatment	Surface treatment in five steps: <ul style="list-style-type: none"> • Alcalically degreased • Phosphated • Dipped in primer (cathaphoretic) • Coated with polyester-epoxy resin powder • Baked (about 400°F) <p>The surface treatment process follows the standard DIN 55900.</p>
Standard color	White, RAL 9016.
Working pressure	87psi
Connections	6 x 1/2"
Certification	ISO 9001 and ISO 14001
Heights	12, 16, 20, 24 and 36 inch
Lengths	Vary by height (16 - 71 inches)
Types	Double Panel
Packaging	Clamp brackets included in the package. Thermostatic valve insert, 1 air vent and 2 installed blind plugs included.



Radiator Dimensions

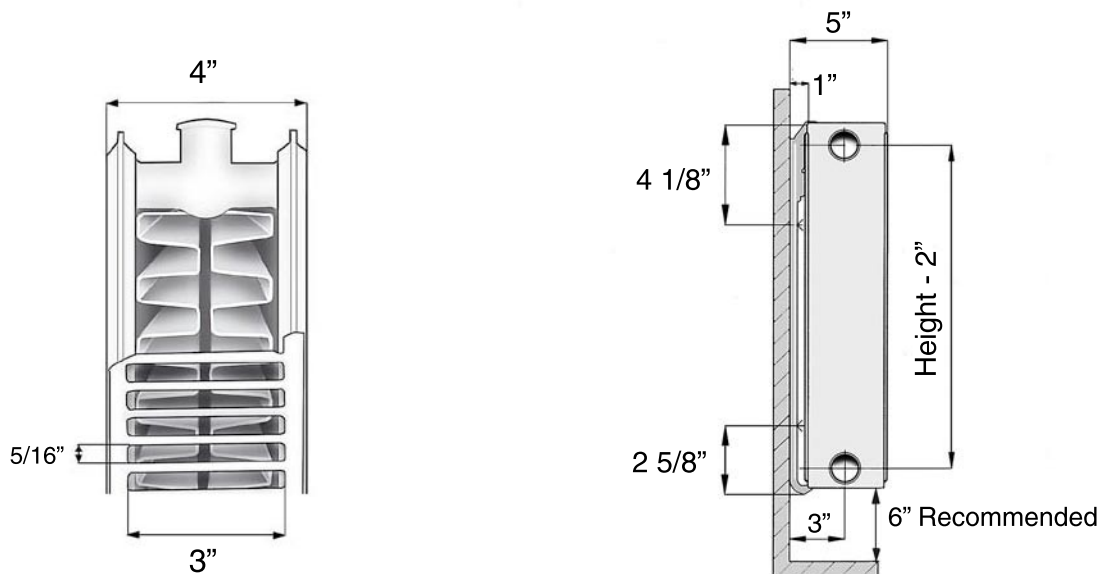

Connections

The integrated valve system is welded onto the radiator during the manufacturing process and is thereafter a fixed part of the radiator. All Biasi Ecostyle radiators are equipped with a built in valve insert suitable for thermostatic sensor heads (purchased separately).

BOTTOM CONNECTION

Thanks to the built in valve system, connection at the bottom is possible. Bottom right hand connection is standard, but the radiators are reversible so left hand connection is possible.

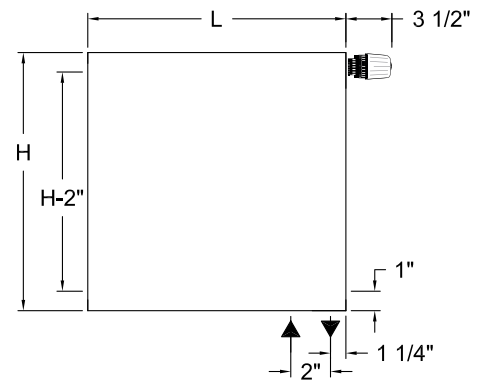

SAME END CONNECTION

Top-bottom same end connection requires external supply and return valves. The bottom connections are to be plugged.



OPPOSITE ENDS CONNECTION

Top-bottom opposite ends connection requires external supply and return valves. The bottom connections are to be plugged.



Note!

The radiator must be connected as above. Faulty connections might cause a heat output decrease.

Ecostyle

Radiator Output Chart

Radiator Model	Height (in)	Length (in)	Output (BTU)	Weight (lbs)	Water Content (gal)
B-12.16 ECO	12	16	1,705	15	0.37
B-12.24 ECO		24	2,562	22	0.53
B-12.32 ECO		32	3,414	29	0.71
B-12.40 ECO		40	4,266	37	0.90
B-12.48 ECO		48	5,119	44	1.08
B-12.56 ECO		56	5,971	51	1.27
B-12.64 ECO		64	6,828	58	1.43
B-16.16 ECO	16	16	2,167	20	0.48
B-16.24 ECO		24	3,254	30	0.71
B-16.32 ECO		32	4,337	40	0.95
B-16.40 ECO		40	5,421	49	1.19
B-16.48 ECO		48	6,504	59	1.43
B-16.56 ECO		56	7,587	69	1.66
B-16.64 ECO		64	8,675	78	1.90
B-16.71 ECO		71	9,758	88	2.11
B-20.16 ECO	20	16	2,610	25	0.58
B-20.24 ECO		24	3,916	37	0.87
B-20.32 ECO		32	5,221	50	1.14
B-20.40 ECO		40	6,526	62	1.43
B-20.48 ECO		48	7,831	74	1.72
B-20.56 ECO		56	9,137	86	2.01
B-20.64 ECO		64	10,442	98	2.30
B-24.16 ECO	24	16	3,037	30	0.69
B-24.24 ECO		24	4,551	45	1.06
B-24.32 ECO		32	6,069	60	1.40
B-24.40 ECO		40	7,587	74	1.74
B-24.48 ECO		48	9,106	89	2.09
B-24.56 ECO		56	10,624	104	2.43
B-24.64 ECO		64	12,138	118	2.80
B-24.71 ECO		71	13,656	133	3.14
B-36.16 ECO	36	16	4,240	46	0.95
B-36.24 ECO		24	6,362	68	1.43
B-36.32 ECO		32	8,480	90	1.90
B-36.40 ECO		40	10,602	112	2.38
B-36.48 ECO		48	12,724	135	2.85

Outputs based on 180° F Supply Temperature, 160° F Return Temperature and 68° F Room Temperature

Radiator Output Correction Factors

Water Temperature		Room Temperature (°F)						
Supply (°F)	Return (°F)	52	56	60	64	68	72	76
200	185	1.38	1.34	1.30	1.26	1.22	1.19	1.14
200	180	1.35	1.32	1.28	1.23	1.20	1.16	1.12
200	175	1.33	1.29	1.25	1.21	1.17	1.14	1.09
200	170	1.30	1.26	1.22	1.18	1.14	1.11	1.07
190	175	1.28	1.24	1.20	1.16	1.12	1.09	1.05
190	170	1.26	1.22	1.18	1.13	1.10	1.06	1.02
190	165	1.23	1.19	1.15	1.11	1.07	1.04	0.99
190	160	1.20	1.16	1.12	1.08	1.05	1.01	0.97
180	165	1.18	1.14	1.10	1.06	1.03	0.99	0.95
180	160	1.16	1.12	1.08	1.04	1.00	0.96	0.92
180	155	1.13	1.09	1.05	1.01	0.97	0.94	0.89
180	150	1.10	1.07	1.03	0.98	0.95	0.91	0.87
170	155	1.09	1.05	1.01	0.96	0.93	0.89	0.85
170	150	1.06	1.02	0.98	0.94	0.90	0.87	0.82
170	145	1.03	0.99	0.95	0.91	0.87	0.84	0.80
170	140	1.01	0.97	0.93	0.88	0.85	0.81	0.77
160	145	0.99	0.95	0.91	0.86	0.83	0.79	0.75
160	140	0.96	0.92	0.88	0.84	0.80	0.77	0.72
160	135	0.93	0.89	0.85	0.81	0.78	0.74	0.70
160	130	0.91	0.87	0.83	0.78	0.75	0.71	0.67
150	135	0.89	0.85	0.81	0.77	0.73	0.69	0.65
150	130	0.86	0.82	0.78	0.74	0.70	0.67	0.62
150	125	0.83	0.80	0.76	0.71	0.68	0.64	0.60
150	120	0.81	0.77	0.73	0.68	0.65	0.61	0.57
140	125	0.79	0.75	0.71	0.67	0.63	0.60	0.55
140	120	0.76	0.72	0.68	0.64	0.60	0.57	0.53
140	115	0.74	0.70	0.66	0.61	0.58	0.54	0.50
140	110	0.71	0.67	0.63	0.58	0.55	0.51	0.47
130	115	0.69	0.65	0.61	0.57	0.53	0.50	0.45
130	110	0.66	0.62	0.58	0.54	0.51	0.47	0.43
130	105	0.64	0.60	0.56	0.51	0.48	0.44	0.40
130	100	0.61	0.57	0.53	0.48	0.45	0.41	0.36
120	105	0.59	0.55	0.51	0.47	0.43	0.40	0.35
120	100	0.56	0.53	0.49	0.44	0.41	0.37	0.32
120	95	0.54	0.50	0.46	0.41	0.38	0.34	0.29
120	90	0.51	0.47	0.43	0.38	0.34	0.31	0.26

