

Non-Condensing Vent Component & Installation Guide

Riva

HEAT ONLY & COMBI BOILER

Please Read This Guide Carefully
and
Save for Future Reference

- This guide is intended to provide detailed information regarding venting components and installation.
- This guide must be used in conjunction with the boiler installation manual.

Prepared by:
QHT, Inc.
Portsmouth, NH
603-334-6400 phone
www.qhtinc.com

Rev. B 04.08.08

Table of Contents:

Restrictor Sizing Chart	4
External Vent Warnings	4
External Vent Clearances	5
Concentric Riser Kit - RI VC RIS 9990322	6
Concentric Riser Kit Installation Instructions	7-9
Standard Concentric Kit - RI VC 9990148	10
Standard Concentric Kit Installation Instructions	11-12
Concentric Vent Accessories	13
RI VC EXT - 9990149	
RI VC 90 - 9990152	
RI VC 45 - 9990153	
Separate Kit - RI VS 8990016	14
Separate Kit Installation Instructions	15-16
Separate Vent Accessories	17
RI VS EXT 9990159	
RI VS 90F 9990160	
RI VS 45 9990162	
RI VS 90M 9990178	
Vertical Roof Vent Kit - RI RV 9990251	18
Vertical Roof Vent Kit Installation Instructions	18-20
Vertical Roof Vent Accessories	21
RI RV EXT 9990242	
RI RV 90 9990256	
RI RV 45 9990255	
RI RV CC 9990275	
Vertical Roof Vent Accessories Cont.	22
RI RV CS 9990276	
RI RV FF 9990280	
RI RV PF 9990252	

Restrictor Sizing Chart

Vent Type	Length (ft)	Restrictor Size
Concentric	1.65 to 3.3	41
	3.3 to 8.8	44
	8.8 to 32.8	None
Separate	1.65 (in) and 1.65 (out)	38
	3.3 to 39.40 (tot. in + out)	41
	39.40 to 131 (tot. in + out)	None
Vertical	3.3 to 27.8	None

Exterior Vent Warnings

CAUTION

EXTERNAL VENT SURFACES ARE HOT.

IT IS THE RESPONSIBILITY OF THE HOMEOWNER TO KEEP THE VENT TERMINAL CLEAR OF SNOW AND ICE.

NOTE: USE ONLY LISTED COMPONENTS SUPPLIED WITH THE BOILER. SURFACE DISCOLORATION OF THE BUILDING MAY OCCUR DUE TO IMPROPER INSTALLATION. QHT, INC. WILL NOT ACCEPT RESPONSIBILITY OF LIABILITY FOR SUCH DISCOLORATION.

Exterior Vent Clearances

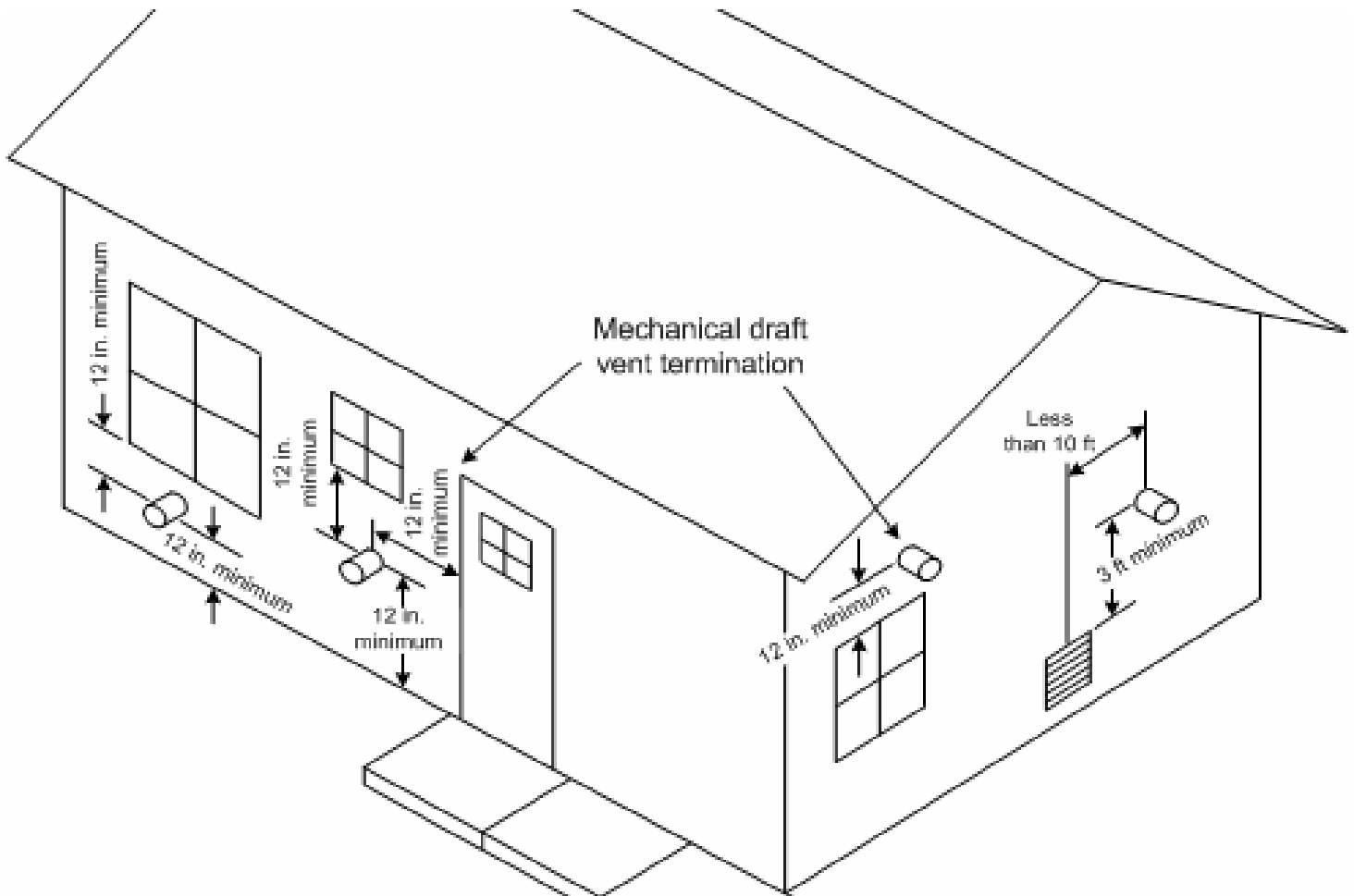

The Exhaust Hood should be installed on the leeward side of the house and conform to the following guidelines:

1. The vent hood shall not be less than 3 feet above any forced air inlet to the house.
2. The vent hood shall not be less than 1 foot below, 1 foot horizontally, or 1 foot above any door, window or gravity inlet into any building.
3. The vent hood shall not be less than 2 feet from an adjacent building.
4. The vent hood shall be not less than 7 feet above grade when located adjacent to a public walkway.
5. The vent hood shall be located so that flue gasses are not directed to jeopardize people, overheat combustible structures, materials or enter buildings.
6. Minimum of 4' horizontal clearance from electric meters, gas meters, regulators and relief equipment.
7. **Care should be taken to ensure the rubber gaskets in ALL vent joints are properly assembled to prevent leakage of products of combustion in the building.**
8. Avoid installing exhaust the hood on the North, West, or the side of the house receiving the prevailing winds.

Concentric Riser Vent Kit - RI VC RIS - 9990322

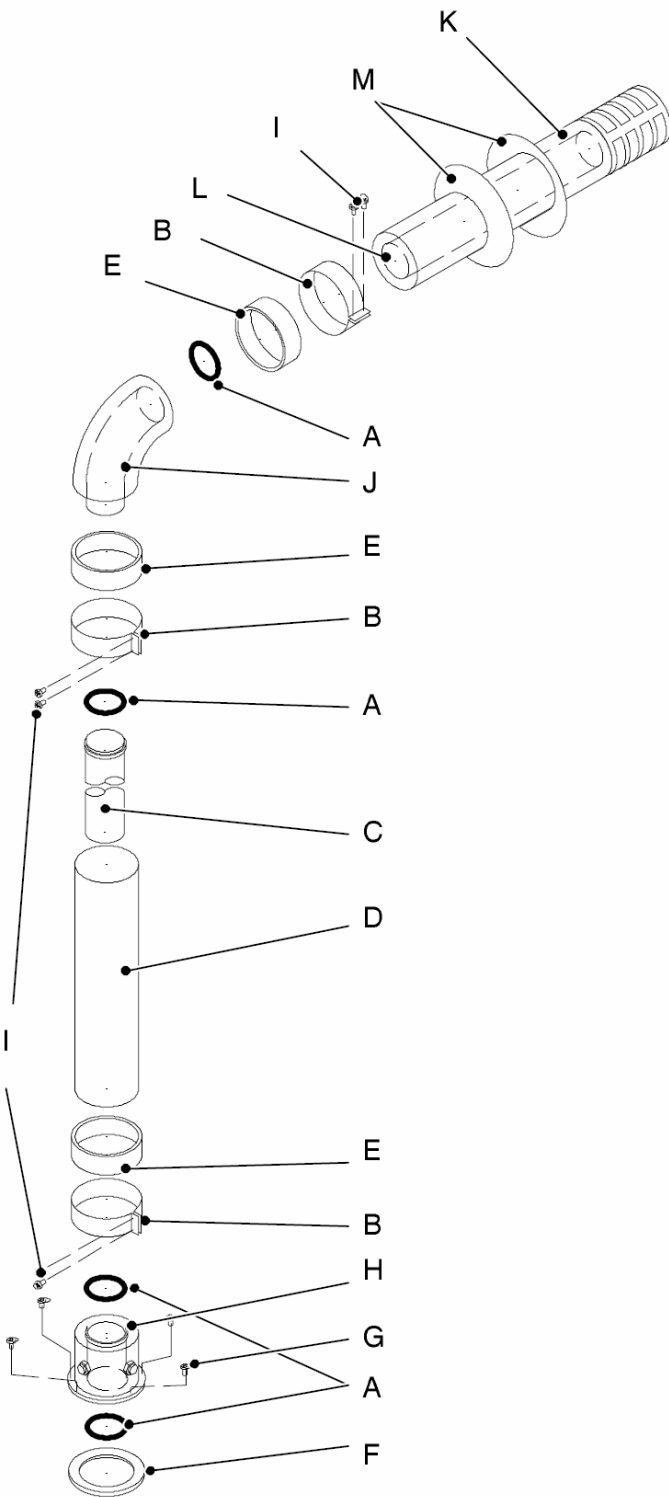

Components included in kit:

- A. EXHAUST GASKET (4)
- B. UNION CLAMP (3)
- C. RISE EXHAUST PIPE (18")
- D. RISE INTAKE PIPE (20")
- E. UNION GASKET (3)
- F. FLANGE GASKET (1)
- G. FLANGE SCREWS (4)
- H. BOILER COLLAR (1)
- I. UNION CLAMP SCREWS (6)
- J. 90 DEG ELBOW (1)
- K. INTAKE TERMINATION (38")
- L. EXHAUST TERMINATION (40")
- M. WALL GASKET (2)

Notes:

Length 1' to 32.8' equivalent length

90 Elbow = 5.4' equivalent length

45 Elbow = 3' equivalent length

Concentric Riser Vent Kit Installation

Pipe connections (Figure 1):

Whenever joining concentric pipe cut the inner exhaust pipe so it is 1 inch long than the outer intake pipe.

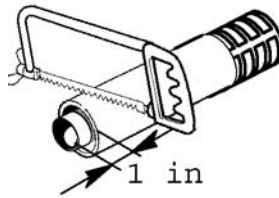

Figure 1

Termination Location / Installation:

The concentric termination piece is installed by sliding the outer intake pipe through the wall from inside the building (shown in figure 2). The inner exhaust pipe is then slid into the intake pipe until the termination cap bottoms out on the end of the intake pipe.

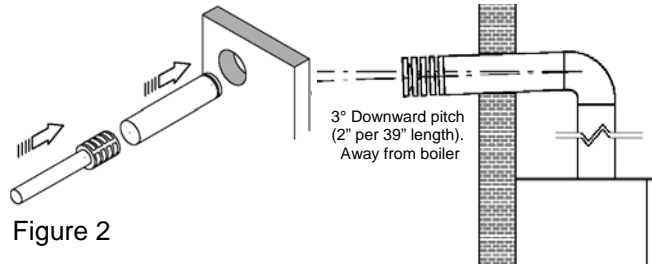

Figure 2

Figure 3

Note: The termination should be pitched 3° downward (2" down per 39" length) away from the boiler. As shown in Figure 3.

Concentric Riser Kit components :

Figure 4 depicts the concentric riser kit components and dimensions. The vertical and horizontal sections can be cut to length (from the male end) during installation. Additional pipe or elbows can be purchased separately. Refer to page 6 for the relevant part numbers.

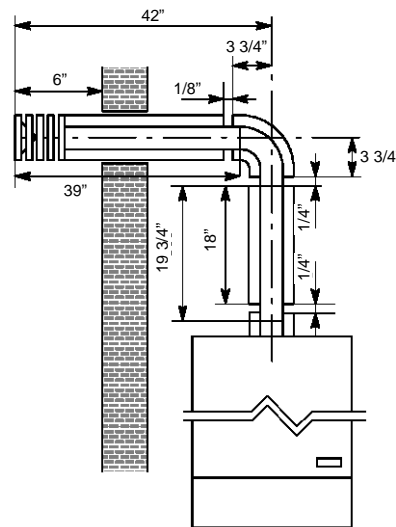

Figure 4

Exhaust Gasket Installation :

Install the red exhaust o-ring gaskets (A) into each of the vent components female ends as shown in Figure 5. Be sure to install the gaskets so the beveled rings are oriented as shown in Figure 5.

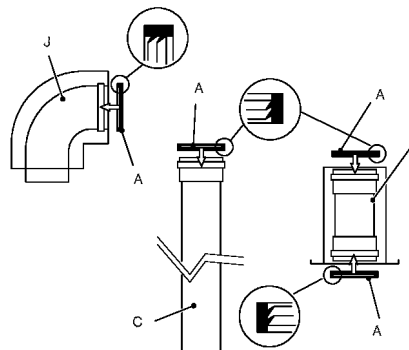

Figure 5

Concentric Riser Vent Kit Installation Cont.

Intake Gasket Installation :

Install the intake gaskets (E) on the intake pipes as shown in Figure 6.

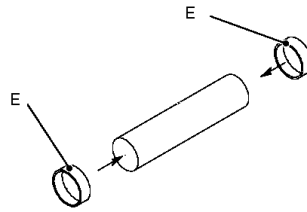

Figure 6

Vertical Rise Installation :

- Install the flange gasket (F) onto the boiler outlet as shown in Figure 7.
- Attach the boiler collar (H) to the outlet of the boiler using the 4 screws (G).
- Insert the vertical exhaust pipe (C) into the boiler collar. (Be careful not to damage the red exhaust gasket)
- Slide the air intake pipe (D) onto the boiler collar so that the intake gasket (E) fits over the intake collar (H).
- Install the elbow (J) onto the vertical rise pipe.

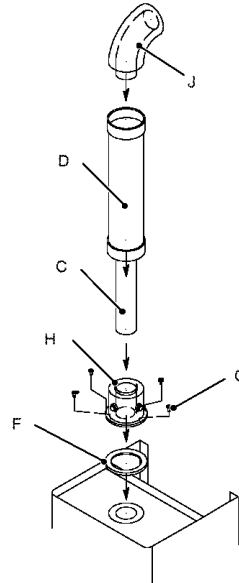

Figure 7

Intake Pipe Clamp Installation :

Install the intake pipe clamps (B) on the intake gaskets (E) as shown in Figure 8, using attachment screws (I)

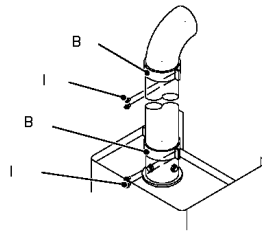

Figure 8

Termination Installation :

- Install the wall gaskets (M) on the termination pipe (K). One gasket from the inside of the wall and one from the outside.
- Install the intake gasket (E) on the termination pipe (K)

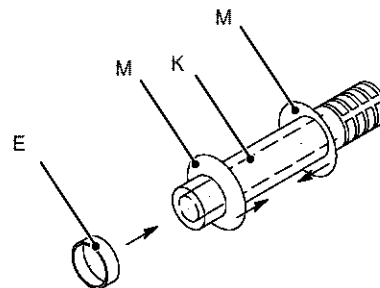

Figure 9

Concentric Riser Vent Kit Installation Cont.

Termination Connection :

- Slide the exhaust termination pipe (L) into the riser elbow (J) until the pipe is securely held by the internal exhaust gasket
- Slide the intake termination pipe (K) and gasket over the intake portion of the riser elbow (J) until the intake gasket fits firmly on the elbow.

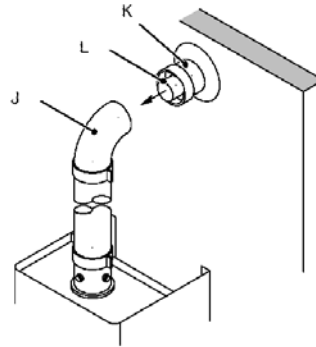

Figure 10

Intake Pipe Clamp Installation :

Install the intake pipe clamps (B) on the intake gaskets (E) as shown in Figure 8, using attachment screws (I)

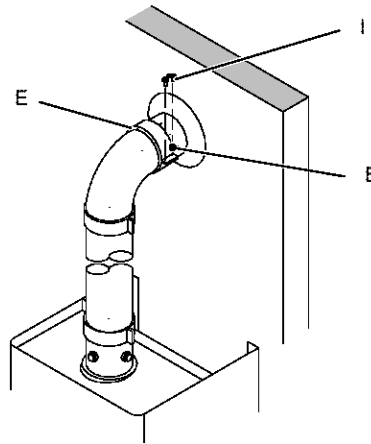
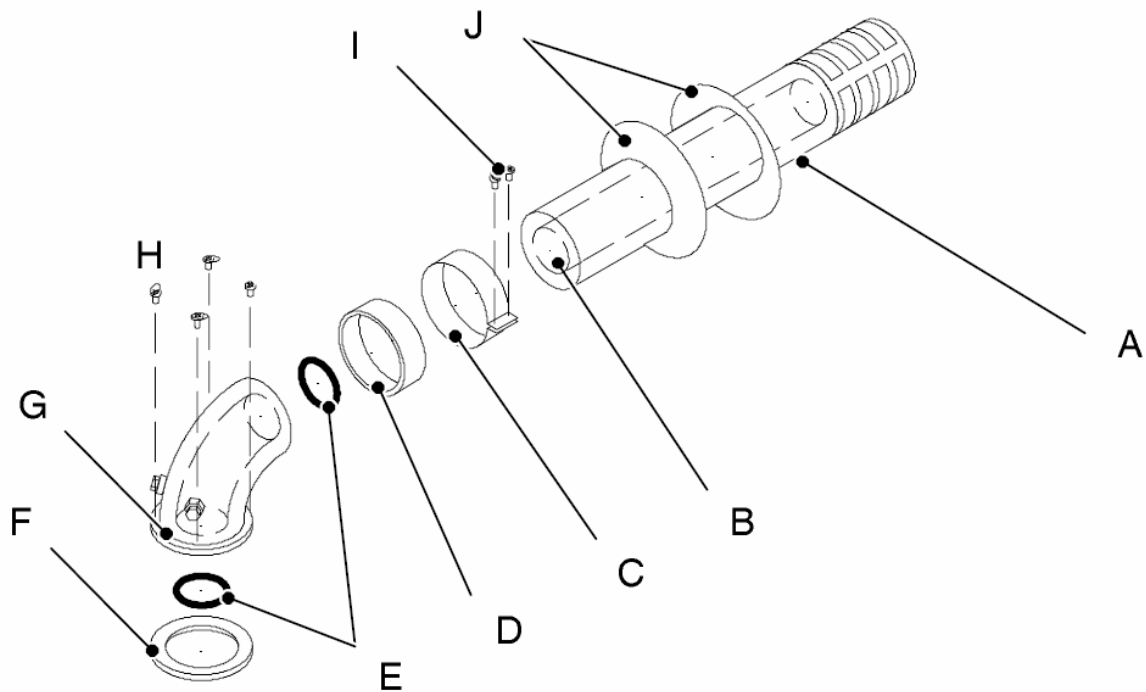

Figure 11

Standard Concentric Vent Kit - RI VC - 9990148



Components included in kit:

- A. INTAKE TERMINATION (38")
- B. EXHAUST TERMINATION (40")
- C. UNION CLAMP (1)
- D. UNION GASKET (1)
- E. EXHAUST GASKET (2)
- F. FLANGE GASKET (1)
- G. 90 DEG ELBOW (W/ FLANGE) (1)
- H. FLANGE SCREWS (4)
- I. UNION CLAMP SCREWS (6)
- J. WALL GASKET (2)

Notes:

Length 1' to 32.8' equivalent length
90 Elbow = 5.4' equivalent length
45 Elbow = 3' equivalent length

Standard Concentric Vent Kit Installation

Pipe connections (Figure 1):

Whenever joining concentric pipe cut the inner exhaust pipe so it is 1 inch long than the outer intake pipe.

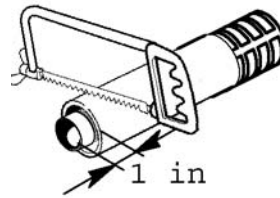

Figure 1

Termination Location / Installation:

The concentric termination piece is installed by sliding the outer intake pipe through the wall from inside the building (shown in figure 2). The inner exhaust pipe is then slid into the intake pipe until the termination cap bottoms out on the end of the intake pipe.

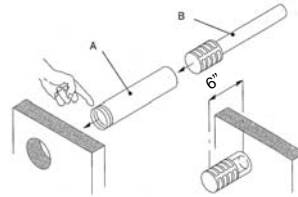

Figure 2

Note: The termination should be pitched 3° downward (2" down per 39" length) away from the boiler. As shown in Figure 3.

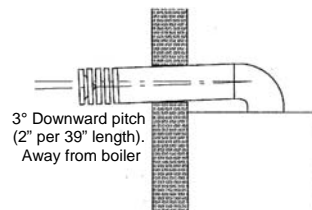

Figure 3

Concentric Vent Kit components :

Figure 4 depicts the standard concentric vent kit components and dimensions. The horizontal termination can be cut to length (from the male end) during installation. Additional pipe or elbows can be purchased separately. Refer to page ? for the relevant part numbers.

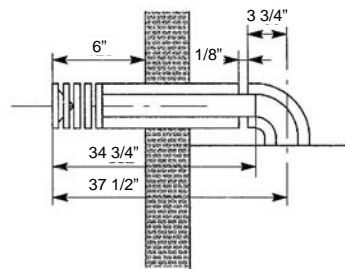

Figure 4

Exhaust Gasket Installation :

Install the red exhaust o-ring gaskets (E) into each of the vent component female ends as shown in Figure 5. Be sure to install the gaskets so the beveled rings are oriented as shown in Figure 5.

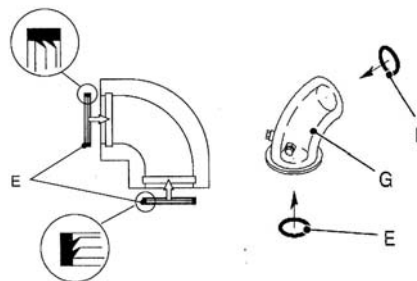

Figure 5

Standard Concentric Vent Kit Installation Cont.

Termination Installation :

- Install the wall gaskets (J) on the termination pipe (A). One gasket from the inside of the wall and one from the outside.
- Install the intake gasket (D) on the termination pipe (A)

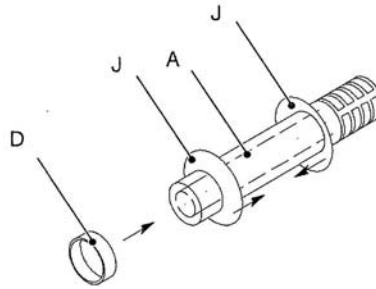

Figure 6

Elbow Installation :

- Install the flange gasket (F) onto the boiler outlet as shown in Figure 7.
- Attach the boiler elbow (G) to the outlet of the boiler using the 4 screws (H).
- Insert the termination exhaust pipe into the elbow. (Be careful not to damage the red exhaust gasket)
- Slide the air intake pipe into the elbow so the intake gasket (D) fits over the elbow (G).

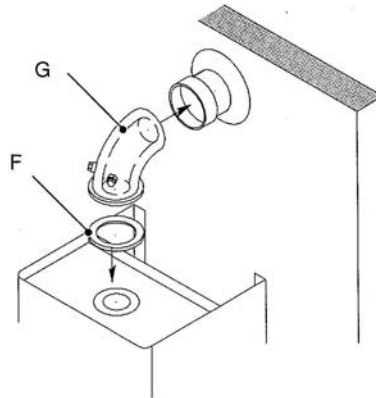

Figure 7

Intake Pipe Clamp Installation :

Install the intake pipe clamp (C) on the intake gasket (D) as shown in Figure 8, using attachment screws (I)

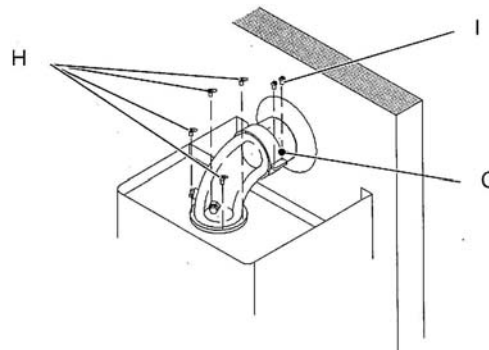
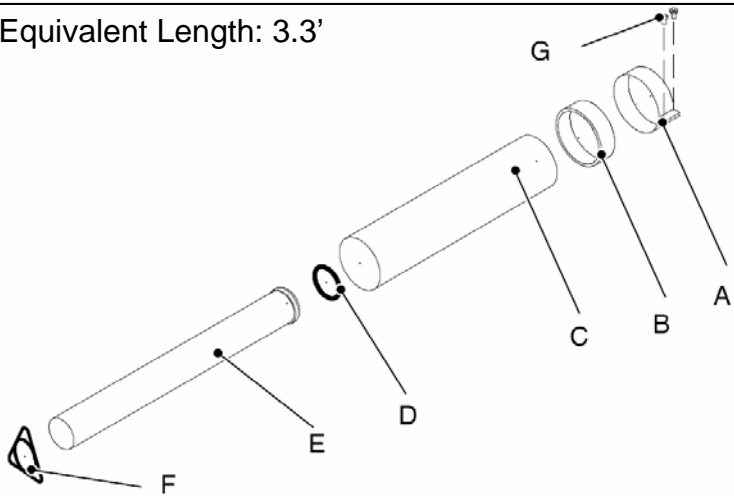

Figure 8

Concentric Vent Accessories

Concentric Extension - RI VC EXT - 9990149

Equivalent Length: 3.3'



Components included in kit:

- A. UNION CLAMP (1)
- B. UNION GASKET (1)
- C. INTAKE PIPE (38")
- D. EXHAUST GASKET (1)
- E. EXHAUST PIPE (40")
- F. EXHAUST PIPE CENTERING BRACKET (4)
- G. UNION CLAMP SCREWS (2)

Concentric 90 Degree Elbow - RI VC 90 - 9990152

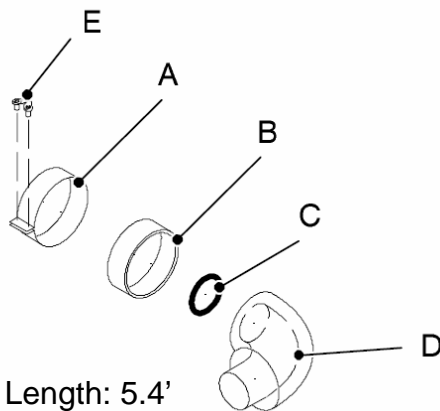

Equivalent Length: 5.4'

Components included in kit:

- A. UNION CLAMP (1)
- B. UNION GASKET (1)
- C. EXHAUST GASKET (1)
- D. 90 DEG ELBOW MALE X FEM. (1)
- E. UNION CLAMP SCREWS (2)

Concentric 45 Degree Elbow - RI VC 45 - 9990153

Equivalent Length: 3'

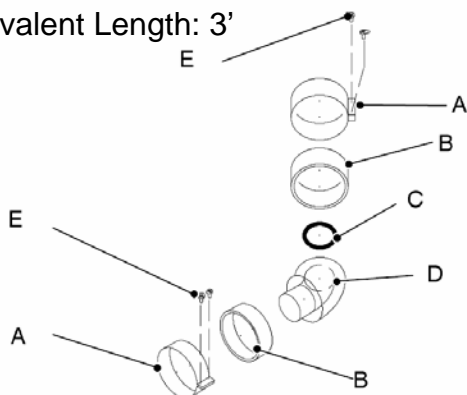

Components included in kit:

- A. UNION CLAMP (2)
- B. UNION GASKET (2)
- C. EXHAUST GASKET (1)
- D. 45 DEG ELBOW MALE X FEM. (1)
- E. UNION CLAMP SCREWS (4)

Separate Vent Kit - RI VS - 8990016

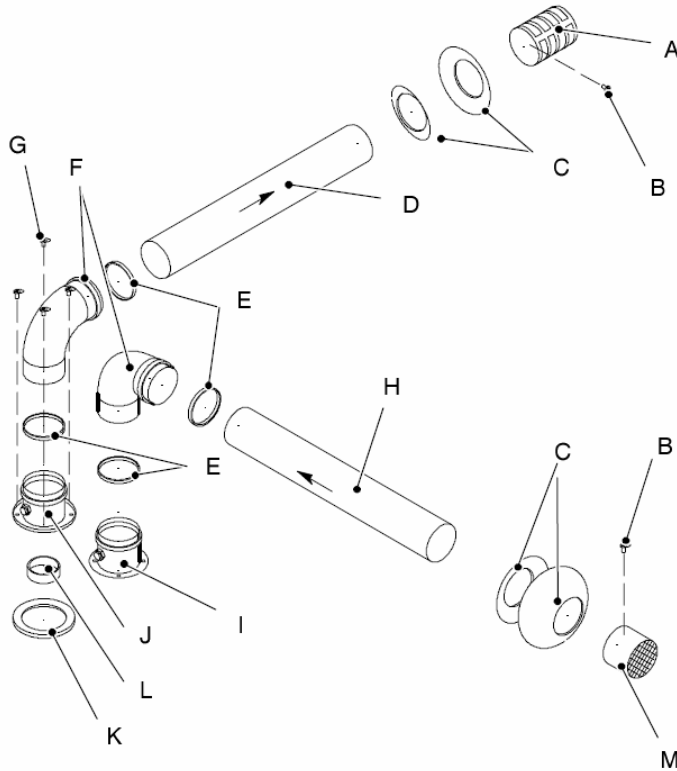

Components included in kit:

- A. EXHAUST TERMINATION (1)
- B. TERMINATION SCREW (2)
- C. WALL GASKET (4)
- D. EXHAUST PIPE (39")
- E. EXHAUST / INTAKE GASKET (4)
- F. 90 DEG ELBOW MALE X FEM. (2)
- G. FLANGE SCREWS (4)
- H. INTAKE PIPE (1)
- I. INTAKE COLLAR (1)
- J. EXHAUST COLLAR (1)
- K. FLANGE GASKET (1)
- L. EXHAUST RESTRICTOR
(SUPPLIED WITH BOILER)
- M. INTAKE TERMINATION (1)

Notes:

Maximum length 131' equivalent length

90 Elbow = 5.4' equivalent length

45 Elbow = 3' equivalent length

Separate Vent Kit Installation

Termination Location / Installation:

Drill the intake and exhaust holes through the external wall according to the boiler mounting diagram supplied in the boiler package. Be sure to account for the 3° downward pitch away from the boiler as shown in Figure 1.

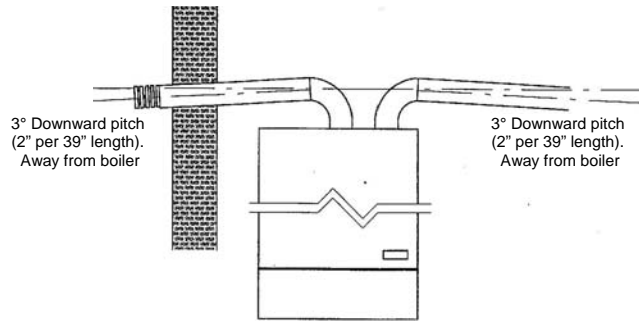

Figure 1

Gasket Installation:

Install the gaskets (E) in the exhaust and intake boiler collars (I,J) and elbows (F), as shown in figure 2.

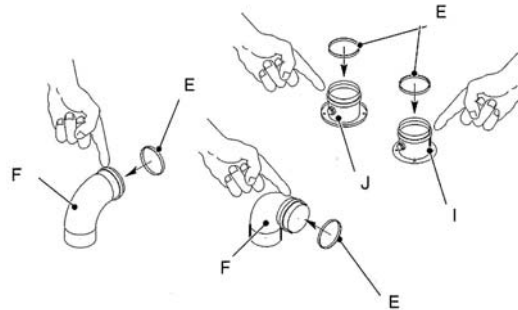

Figure 2

Termination Installation :

Install the intake (H) and exhaust (D) terminations through the corresponding exterior walls as shown in Figure 3. Slide the wall gaskets (C) onto each of the pipes to secure the pipe against the wall.

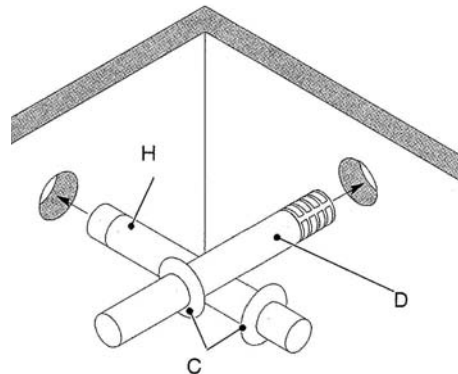

Figure 3

Exhaust Collar Installation :

Mount the exhaust gasket (K) on the exhaust outlet of the boiler as shown in Figure 4. Install the appropriate flue restrictor ring (L) according to the table on page ?. Secure the Exhaust Collar (J) to the top of the boiler using the 4 screws (G) supplied.

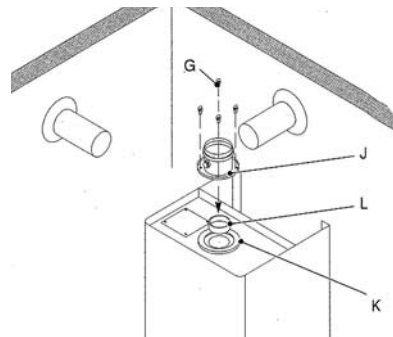

Figure 4

Separate Vent Kit Installation Cont.

Intake Installation :

Remove the intake cover plate. Install the intake gasket over the intake hole. Mount the intake collar (I) with the 4 screws (G) supplied, as shown in figure 5.

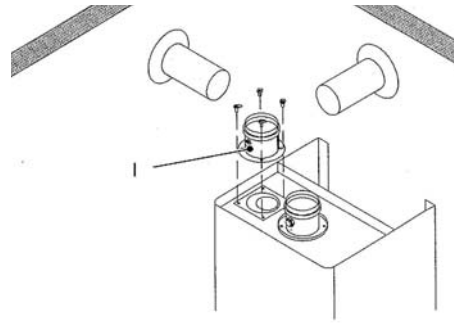

Figure 5

Elbow Installation : Figure 6

- Install the exhaust elbow (F) onto the exhaust collar (J).
- Install the intake elbow (F) onto the intake collar (I).
- Slide each termination (intake & exhaust) into the corresponding elbow.
- Slide the external wall gaskets onto the terminations until they are seated against the building.

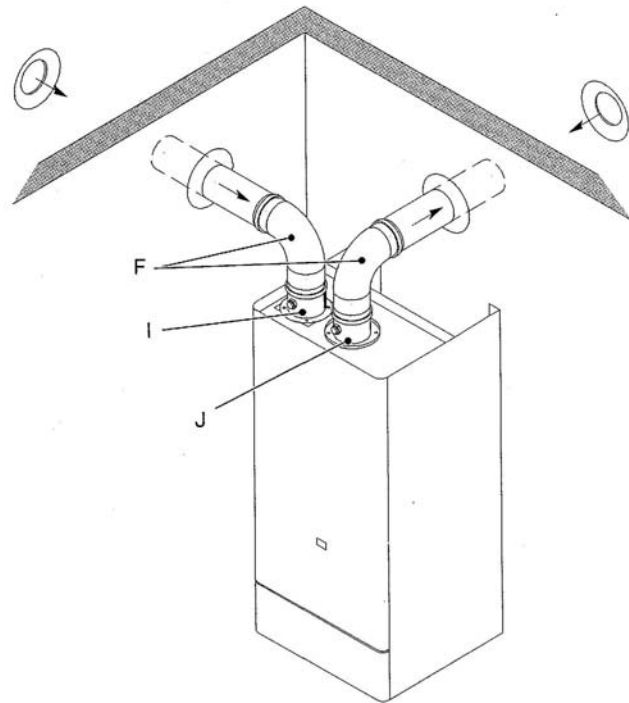
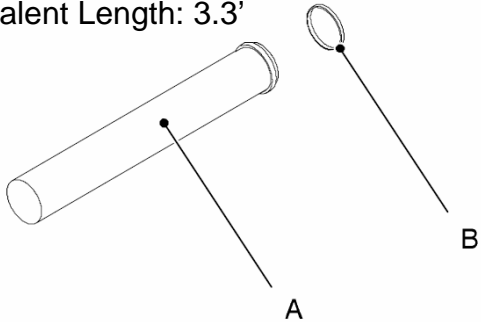

Figure 6

Separate Vent Accessories

Separate Extension - RI VS EXT - 9990159

Equivalent Length: 3.3'



Components included in kit:

- A. INTAKE / EXHAUST EXTENSION (39")
- B. INTAKE / EXHAUST GASKET (1)

Separate 90 Degree F X F Elbow - RI VS 90F - 9990160

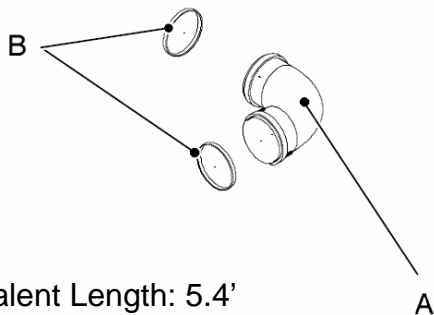

Equivalent Length: 5.4'

Components included in kit:

- A. 90 DEGREE FEM. X FEM. ELBOW (1)
- B. INTAKE / EXHAUST GASKET (1)

Separate 45 Degree Elbow- RI VS 45 - 9990162

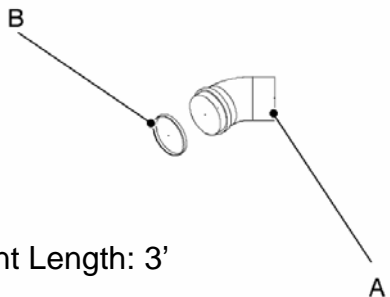

Equivalent Length: 3'

Components included in kit:

- A. 45 DEGREE MALE X FEM. ELBOW (1)
- B. INTAKE / EXHAUST GASKET (1)

Separate 90 Degree M X F Elbow - RI VS 90M - 9990178

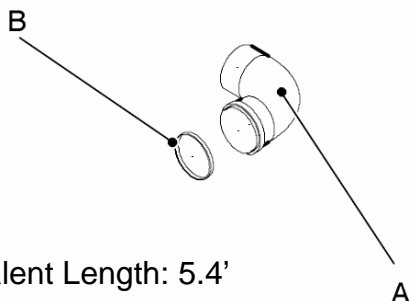

Equivalent Length: 5.4'

Components included in kit:

- A. 90 DEGREE MALE X FEM. ELBOW (1)
- B. INTAKE / EXHAUST GASKET (1)

Vertical Roof Vent Kit - RI RV - 9990251

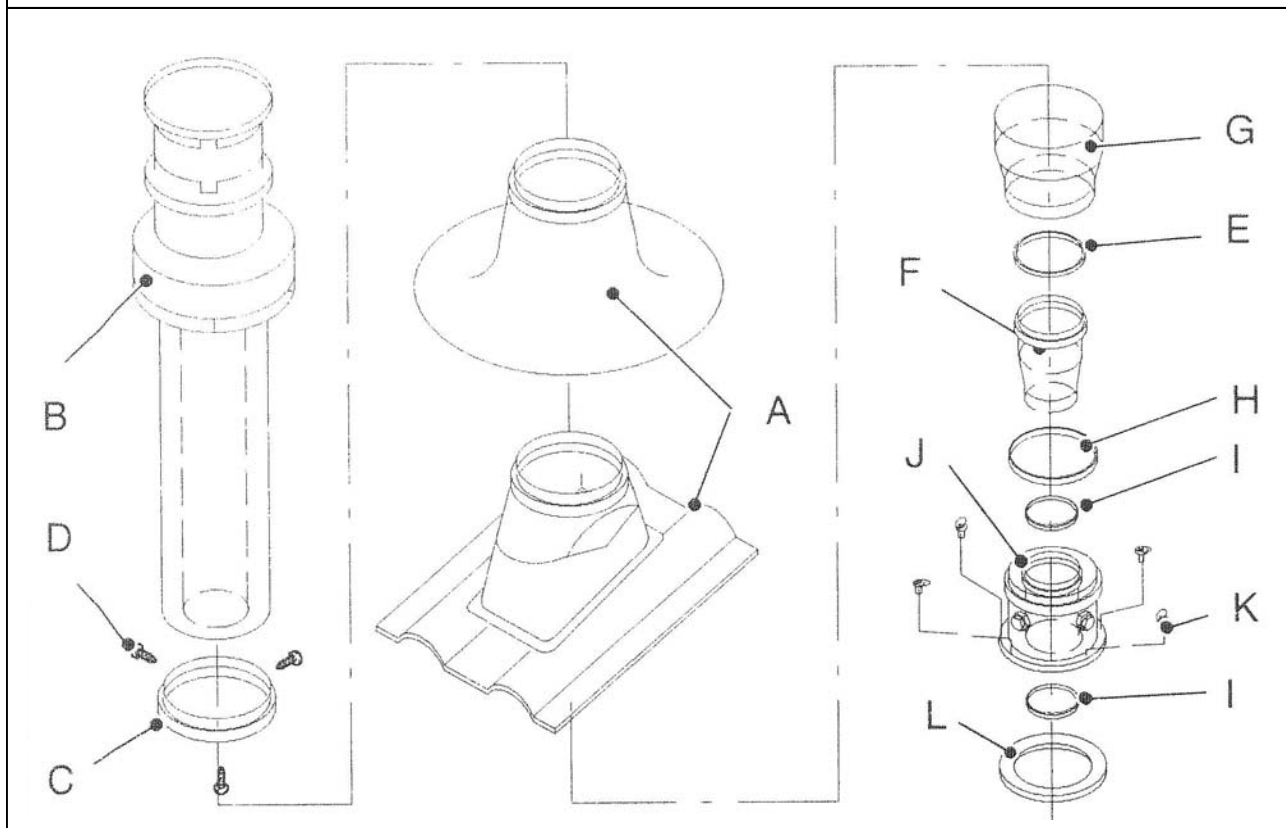

Components included in kit:

- A. ROOF FLASHING - FLAT / PITCHED* (1)
- B. EXTERIOR TERMINATION (1)
- C. TERMINATION FLANGE (1)
- D. TERMINATION MOUNTING SCREW (3)
- E. EXHAUST ADAPTER GASKET (1)
- F. EXHAUST ADAPTER (1)
- G. INTAKE ADAPTER (1)
- H. INTAKE GASKET (1)
- I. EXHAUST GASKET (2)
- J. BOILER COLLAR (1)
- K. BOILER COLLAR MOUNTING SCREWS (4)
- L. BOILER FLANGE GASKET (1)

* Must be purchased separately. Part numbers can be found on page ?

Notes:

- Maximum height 27.8' equivalent length
- 90 Elbow = 3.3' equivalent length
- 45 Elbow = 1.6' equivalent length
- Maximum 4 elbows (45 or 90)
- When equivalent height is greater than 9.8' a condensate collector and siphon must be used (see accessories page for the part numbers)

Vertical Roof Vent Kit Installation

Termination Location / Installation: Figure 1
Before installing the roof termination, ensure the proposed location meets the clearance requirements in the boiler installation manual and any local code requirements.

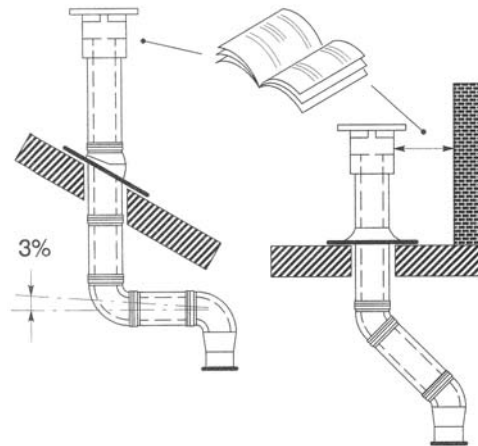

Figure 1

Standard Roof Vent Height:

The standard roof vent kit is 53.5 inches from the top of boiler to the top of the termination. Extensions and elbows can be added, as needed. These parts are shown on page ?. The pitched roof flashing can accommodate a 16° to 41° pitch, as shown in figure 2. Note: The roof flashing (pitched or flat) must be purchased separately.

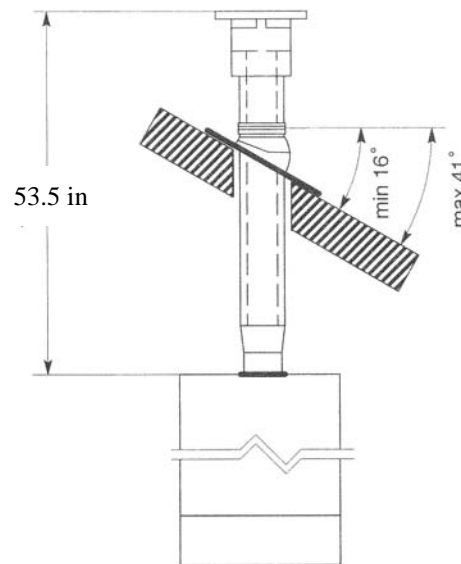

Figure 2

Termination Installation :

- Slide the termination flange (C) onto the termination pipe (B) as shown in figure 3.
- Align the roof flashing (A, purchased separately) with the hole cut through the roof.
- Slide the termination (B) down through the flashing and hole through roof until the termination flange (C) fits securely on the roof flashing.

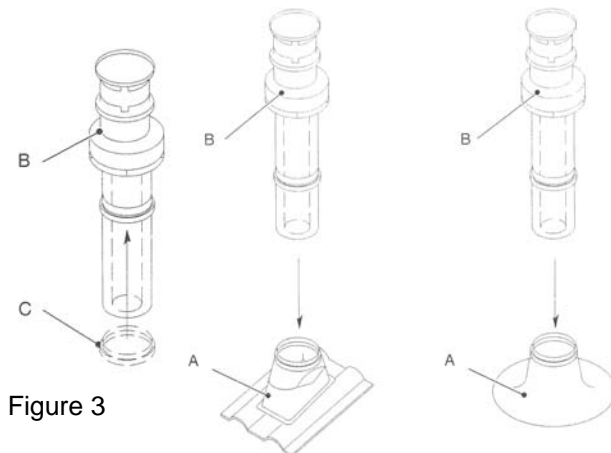

Figure 3

Figure 4

Vertical Roof Vent Kit Installation Cont.

Gasket Installation :

Insert the gaskets (E,H,I) into the corresponding adapters as shown in figure 5. Be sure to install the gaskets so the bevels of the gasket are oriented as shown.

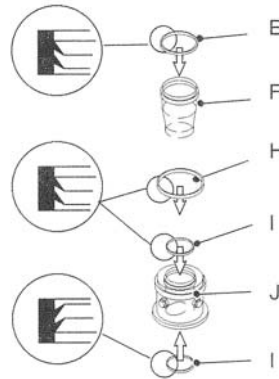

Figure 5

Boiler Collar Installation : Figure 6

- Install the intake gasket (L) onto the flue outlet of the boiler.
- Attach the boiler collar (J) to the boiler using the 4 screws (K).
- Slide the adapters (F, G) into the collar (J). Be sure not to damage the gaskets.

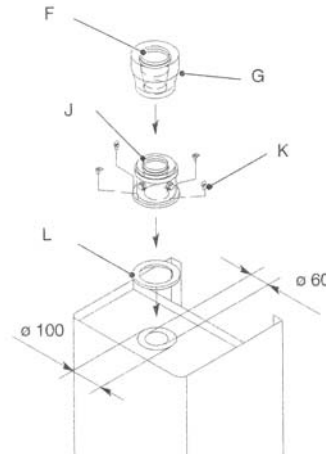

Figure 6

Boiler connection :

Slide the termination or extension (if used) into the adapters (F, G) as shown in figure 7.

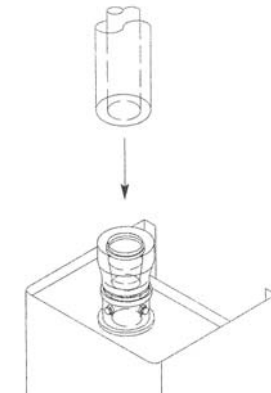

Figure 7

Final Installation :

Once the exhaust pipe has been connected to the boiler, installation is completed by sliding the termination flange (C) down onto the roof flashing (A). Secure the flange with the three supplied screws (D) as shown in figure 8.

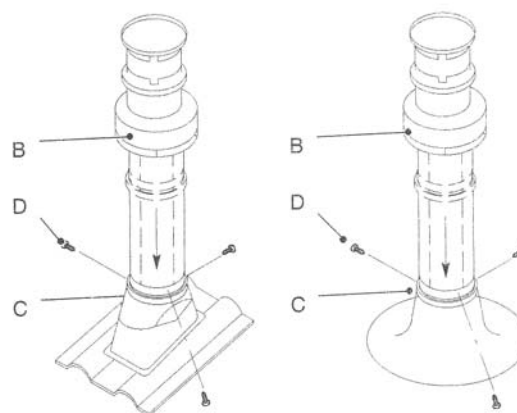
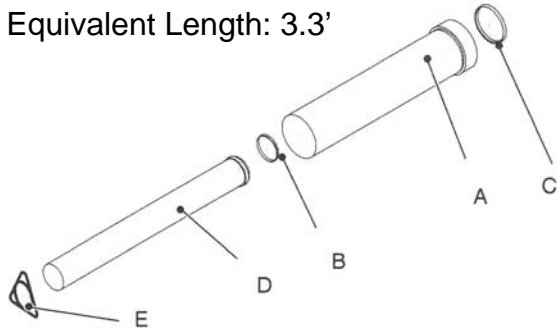

Figure 8

Vertical Roof Vent Accessories

Vertical Roof Vent Extension - RI RV EXT - 9990242

Equivalent Length: 3.3'



Components included in kit:

- A. INTAKE EXTENSION (39")
- B. EXHAUST GASKET (1)
- C. INTAKE GASKET (1)
- D. EXHAUST EXTENSION (39")
- E. CENTERING BRACKET (1)

Vertical Roof Vent 90 Degree Elbow - RI RV 90 - 9990256

Equivalent Length: 3.3'

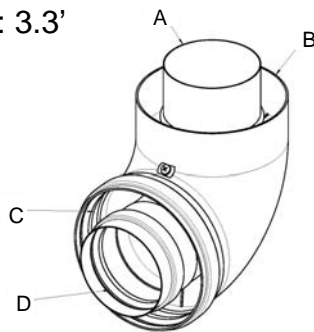

Components included in kit:

- A. EXHAUST PIPE (1)
- B. INTAKE PIPE (1)
- C. INTAKE GASKET (1)
- D. EXHAUST GASKET (1)

Vertical Roof Vent 45 Degree Elbow- RI RV 45 - 9992551

Equivalent Length: 1.6'

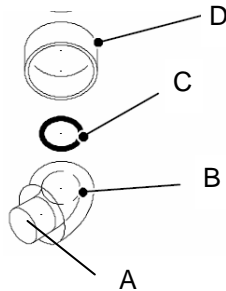

Components included in kit:

- A. EXHAUST PIPE (1)
- B. INTAKE PIPE (1)
- C. EXHAUST GASKET (1)
- D. INTAKE GASKET (1)

Vertical Roof Vent Condensate Collector - RI RV CC - 9990275

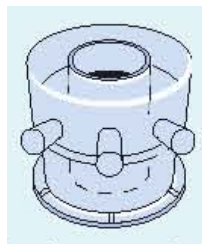

Note: Must be used when total equivalent height is greater than 9.8'

Vertical Roof Vent Accessories Cont.

Vertical Roof Vent Condensate Siphon - RI RV CS - 9990276.1



Note: Must be used with the condensate collector when the total equivalent height is greater than 9.8'

Vertical Roof Vent Flat Flashing - RI RV FF - 9990280

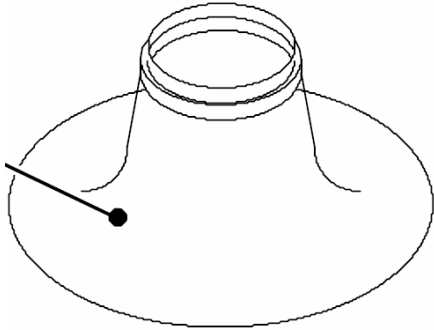

Vertical Roof Vent Pitched Flashing - RI RV PF - 9990252

